

VIEW NTS **A** BASE PLATE DETAIL
5mm BASE PLATE
FIX WITH M10 CHEM/MECH ANCHOR
TYPICAL DETAIL

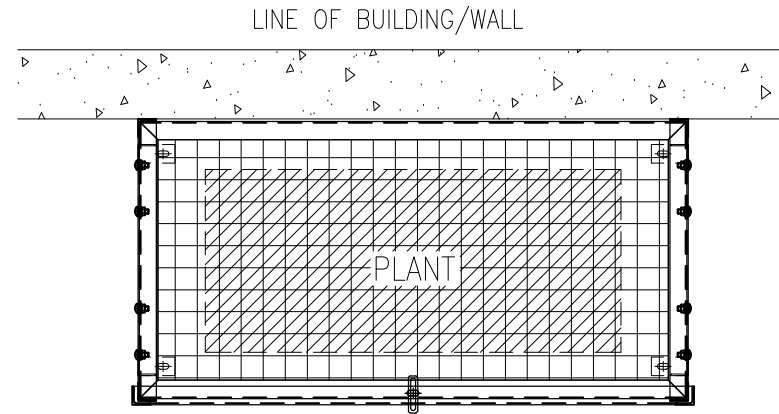

VIEW Scale NTS **1**

NOTES! DPTI STANDARD = 25x25x3.15 316 S/S WELDMESH.
PANELS TO BE FABRICATED FROM 40x40x3 316S/S EQUAL ANGLE, 25x25x3.15 OR 50x50x4.0316 S/S WELDMESH. TO BE CONFIRMED PRIOR TO FABRICATION.
LINSH OUTSIDE WELDS TO SMOOTH FINISH.
PANELS TO INTERLOCK ON ASSEMBLY, BOLT SIDE & TOP PANELS TOGETHER.
PADLOCK TO SECURE FRONT PANEL IN PLACE.
FIX IN PLACE WITH M10 CHEM ANCHOR, 80mm MIN EMBEDMENT.
WHERE POSSIBLE, PANELS TO BE SUPPLIED 'FLAT PACKED' TO SITE.
SPECIAL ORDERS MAY REQUIRE WORKSHOP ASSEMBLY, AND SOME SITE ASSEMBLY.
IF SITE WELDING IS REQUIRED, ALL WELDS TO BE TOUCHED UP WITH ZINC RICH PRIMER, AND NEAT APPLICATION OF SILVERFROST.

CONDENSER CAGES STOCK SIZES.
OR AS PER ORDER

CAT. NO.	DIMENSIONS		
	Width	Height	Depth
25MM MESH			
090906/25	900	900	600
100906/25	1000	900	600
121006/25	1200	1000	600
121206/25	1200	1200	600
121406/25	1200	1400	600
121606/25	1200	1600	600
121806/25	1200	1800	600
50MM MESH			
090906/50	900	900	600
100906/50	1000	900	600
121006/50	1200	1000	600
121206/50	1200	1200	600
121406/50	1200	1400	600
121606/50	1200	1600	600
121806/50	1200	1800	600

FLOOR MOUNTED STYLE standard or optional WALL MOUNT

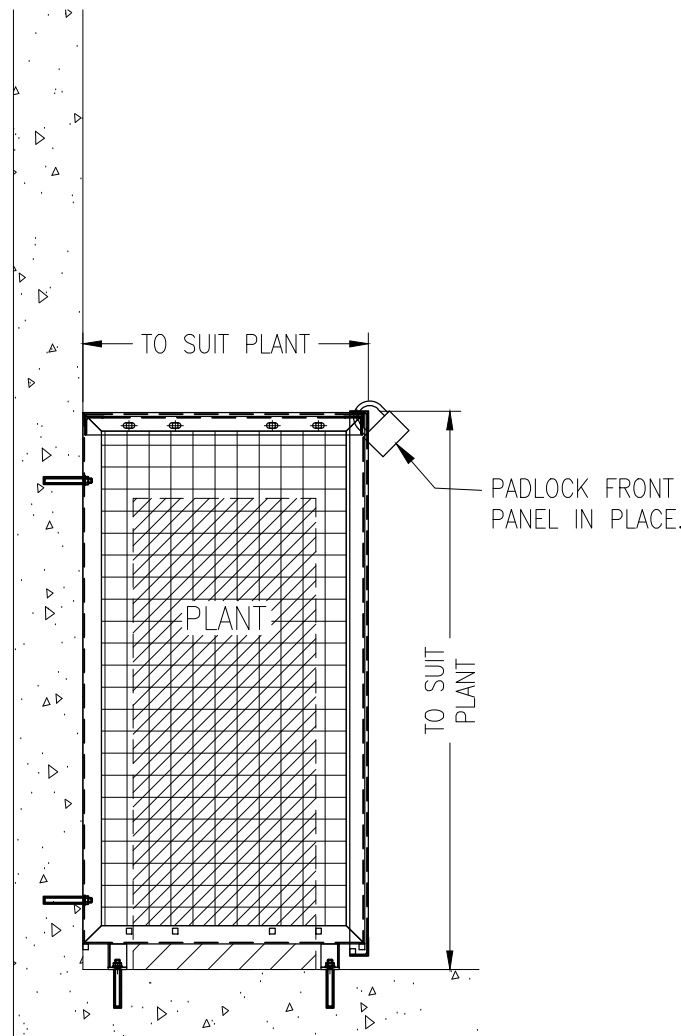

VIEW Scale NTS **2**

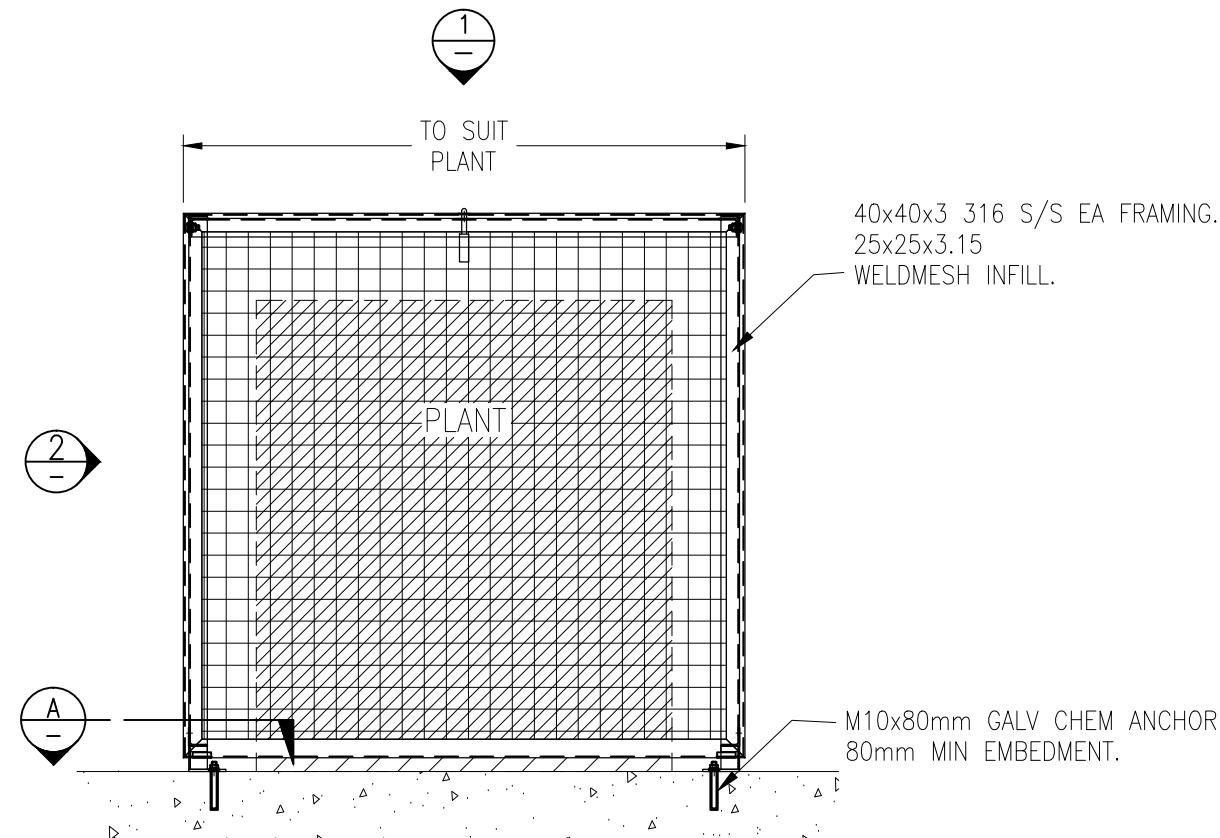

DETAIL **E1** PLANT ENCLOSURE ELEVATION
FABRICATED SIZE TO SUIT ORDER
40x40x3 316 S/S EQUAL ANGLE FRAME
25x25x3.15 316 S/S WELDMESH
REMOVE ALL SHARP EDGES.
M10 CHEM/MECH ANCHORS

SAXON ENGINEERING

23 HEATH STREET LONSDALE
SOUTH AUSTRALIA 5160
AUSTRALIA. Ph 08 8187 2888. Fax 08 8326 8654
EMAIL. sales@saxonengineering.com.au
admin@saxonengineering.com.au

THIS DOCUMENT IS COPYRIGHT AND REMAINS THE PROPERTY OF SAXON ENGINEERING, AND MUST NOT BE USED, REPRODUCED OR COPIED, WHOLLY OR IN PART, WITHOUT THE WRITTEN PERMISSION OF SAXON ENGINEERING.

0	--	---/---/---		
0	ISSUE FOR INFORMATION	13/07/17		
REV	DESCRIPTION	DATE		
TITLE: PLANT ENCLOSURE SINGLE BAY ENCLOSURE (S/S SPECS)				
SITE:				
CLIENT:				
SCALE (S) AS SHOWN		JOB No:		
DRAWN	CHECKED	SIZE	DRAWING NUMBER	REV.
TAG		A3	PE-01-01 (SS)	0
13/07/17				